

INTRODUCTION

Most pallet manufactures are committed to recycle the pallets and keeping wooden packaging out of our landfills. I nevertheless see a huge amount of pallets abandoned in the streets of London every day.

The pallet market is becoming a significant element in UK and European distribution and this seems to be reflected in our environment. A recent study claimed that

“...the market capacity in the UK is 120,000 pallets a night...” (KPMG).

The market growth rate too is displaying some startling characteristics with recent annual growth rates claimed varying from 20% to 40%.

This lead me to choose to work with wooden pallets for my 10, TEN, X project and I've been amazed by the possibilities of building all kind of furniture out of pallets. All for free - if you've got the time and a few essential tools.



Different pallet designs

A pallet seems to come in many different sizes and designs but I have found that the two main designs are Stringer design and Block design. See illustration.

The Stringer pallets are easier to get apart and I prefer them to the Block design - unless you are going to use the blocks.

PRINCIPAL PARTS OF WOODEN PALLETS

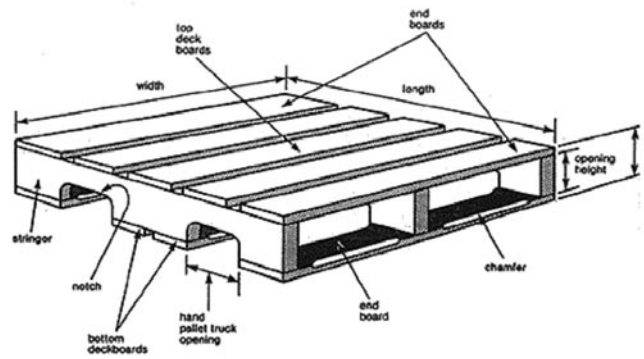

Stringer Design

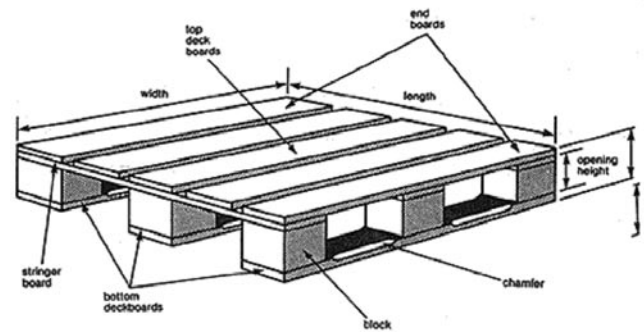

Block Design

Tips

When you pick your pallets - take the pallets with as few nails in as possible. There will be some waste as some of the boards often get damaged when you take the pallets apart.

TOOLS

Essential tools to take the pallets apart are a big crow bar and a heavy duty hammer. When making the piece of furniture any kind of electrical jigsaw, mitre saw or table saw are handy to have - but a good old fashioned saw will also do the job.

MAKING YOUR CHAIR
STEPS 1-5 OVERVIEW

1. Find a couple of pallets. You need to find one with quite thin 12mm planks and one with more normal 16mm plank thickness.
2. Take the pallets apart. This can be a bit of a struggle but I always find that my big crowbar does the job.
3. Cut all the elements needed to size - as showed in Drawing 1.
4. Make sure you have the accessories needed to finish the lamp
 - ❑ 2 bolts + matching wing nut 2"
 - ❑ 42 twin thread woodscrews 6x 1.1/4"
 - ❑ 8 twin thread woodscrews 10 x 2"

5. You can now assembly the chair following the illustrations on page 5.

For more information on this and other products visit studiomama.com or email tolstrup@studiomama.com

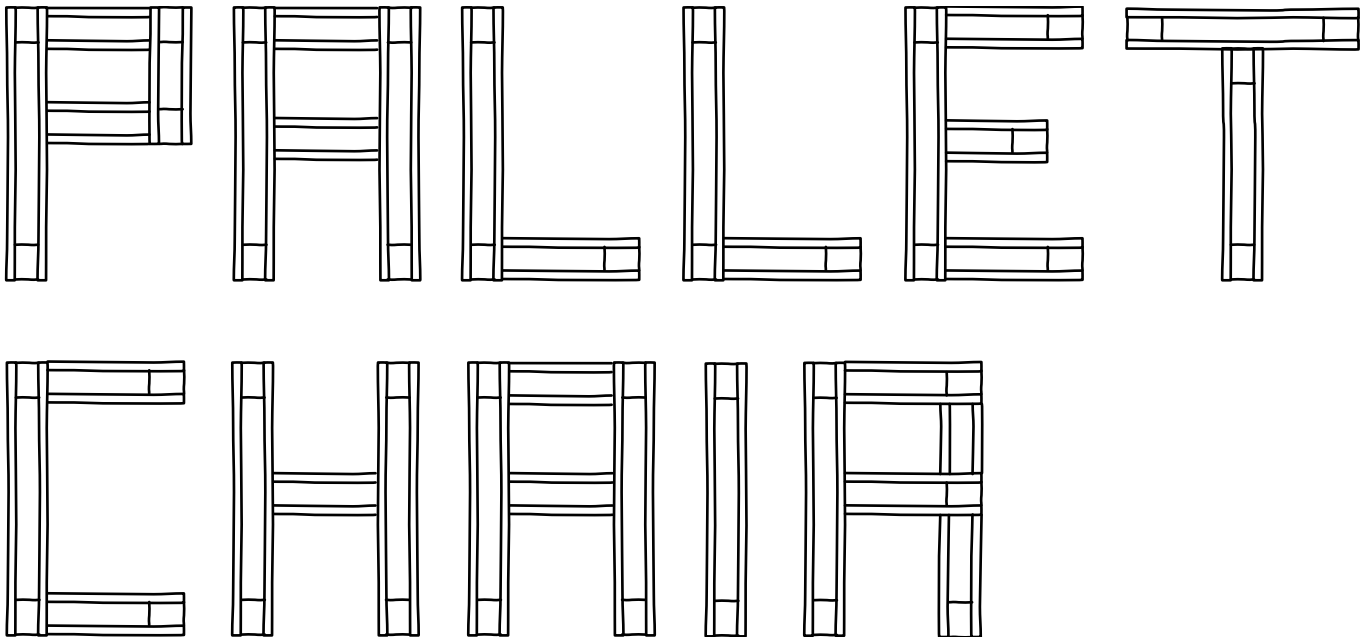

DRAWING 1

Cut up the following elements from pallets

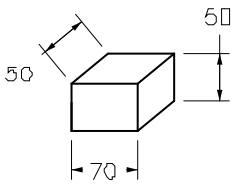

2 x (16x380x70mm) inside frame

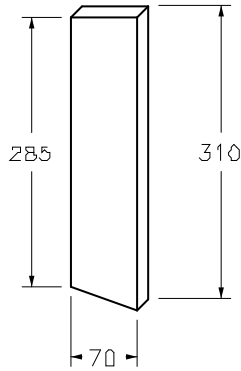

End has to be cut with a 20 degree angle

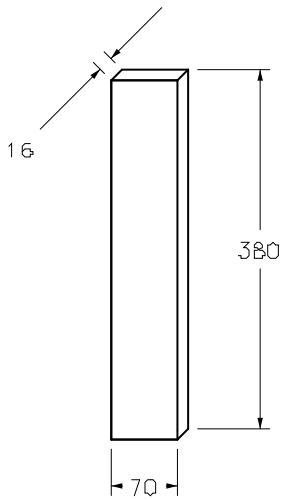

2 x (16x70x680mm frame legs)

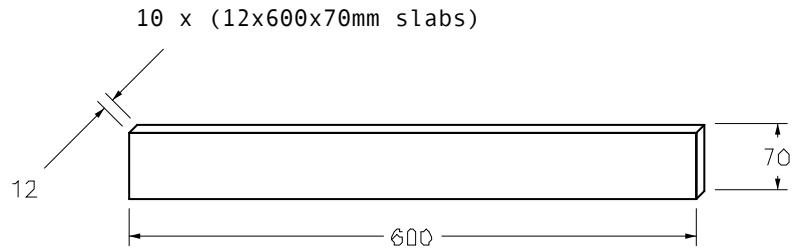

10 x (12x600x70mm slabs)

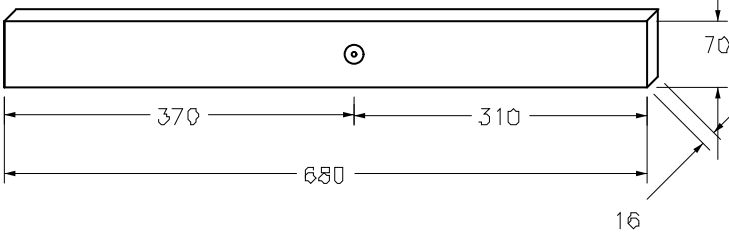

Cut a 5mm hole through the plank centred 370mm down from the top. Drill an inserted hole 6mm into the surface, so the screw is slightly inserted into plank.

2 x (16x480x70mm back)

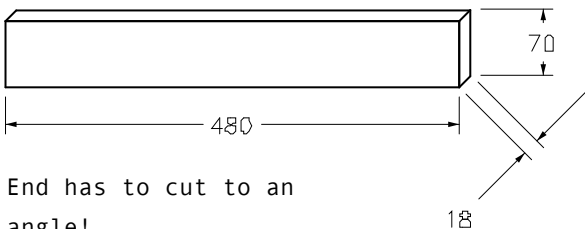

End has to cut to an angle!

ASSEMBLY INSTRUCTIONS

Always predrill the holes with a small drill 1 or 2mm - so the wood does not split when you screw into it. Pre-drill to countersink the screws.

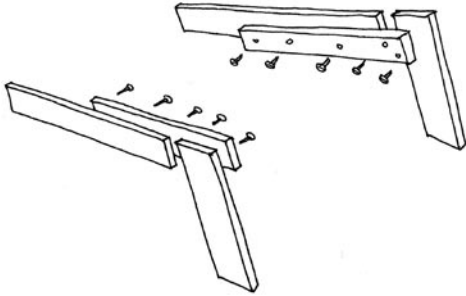

1. Start with screwing the legs together. If you have clamps - they are helpful to keep the pieces together while putting it together

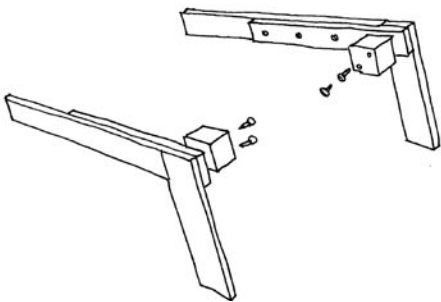

2. Screw the blocks in with the long screws.

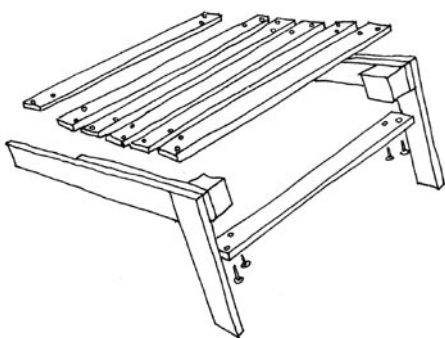

3. Fit the first 5 planks on to the leg frame. Leave about 5mm between the planks. Make sure the screw goes into the centre of the back plank. You need a tight fit between the 6th end plank and the back of the chair. The gap between planks has to be 7mm. You can also wait and put the last plank on when the back is ready. Fix the 7th plank underneath the blocks.

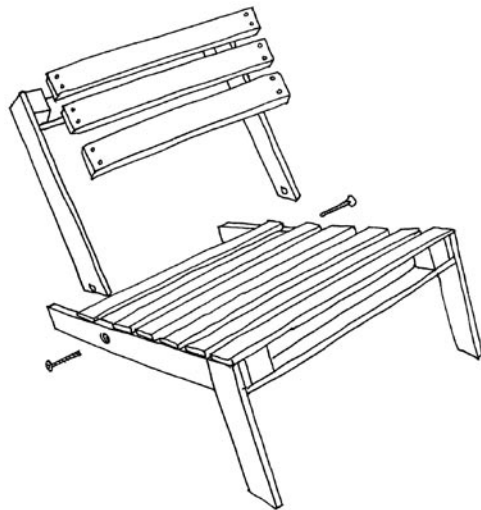

4. Screw the back parts together. First the side planks and the blocks with the last 4 long screws and then the back plank.

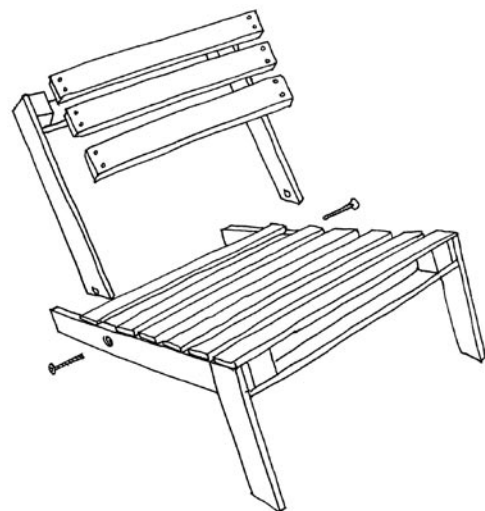

5. You can now fix the last 3 planks to the frame of the back of the chair. Now put the two parts of the chair together - joined by the bolt and wing screws. If you waited putting the last plank on to the seating part of the chair, put it tight against the back and screw it down. You can give the chair a light sanding if needed to remove splinters.